

University of California at Santa Cruz
 Jack Baskin School of Engineering
EE-171L: Analog Electronics Lab
Laboratory 4
Ali Shakouri, 4/3/2003 Revised Peter Holm, W-04

Name: _____

Partner: _____

Introduction to JFETs

I. DESCRIPTION AND OBJECTIVES

Basic electrical properties of an n-channel JFET operating in cutoff, triode and saturation modes are observed and investigated. A common-source amplifier biased to operate in saturation is constructed to gain insight into ac small-signal behavior.

II. COMPONENTS AND INSTRUMENTATION

Components should be available from your lab kit or obtained from your lab instructor. We will be using the 2N5486 (or similar) n-channel JFET for both circuits. These devices are electrically and physically fragile. Avoid bending the leads unnecessarily, especially at the point where the leads go into the plastic case. They have a tendency to fall off if mistreated! Be sure to use the same JFET for the first parts of this lab since I_{DSS} and V_{i0} will vary between devices.

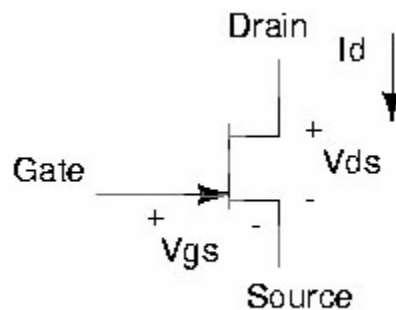

Figure 1. Symbol and pinout for an n-channel JFET.

Note: Re-draw this schematic in your engineering notes and make any experimental scribbles or annotations there.

III. DEVICE CHARACTERIZATION

Using the circuit in Figure 2, take data to provide a Plot of I_D vs. V_{GS} . Label where I_{DSS} and V_{i0} occur. $V_{dd} = 15V$.

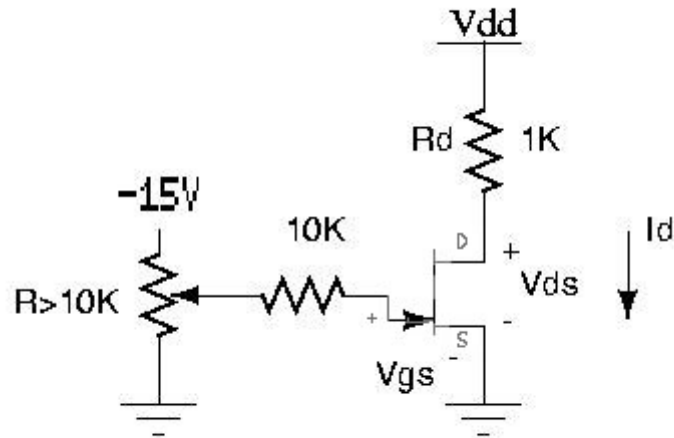

Figure 2. Circuit used to find basic parameters.

NOTE: Re-draw all schematics in your engineering notes and make any experimental scribbles or annotations there.

Recommended procedure: The circuit shown Figure 2 allows only negative values of v_{GS} thus always keeping the device reversed biased at the gate. Take a set of measurements varying v_{GS} from zero to well past the pinch-off voltage V_{t0} to be able to accurately Plot I_D vs. v_{GS} and identify where V_{t0} occurs. I_{DSS} by definition is the drain current with $v_{GS} = 0$. You will need these two quantities for the common-source amplifier and to theoretically analyze experimental results in your report. Remember to calculate I_{DSS} from the floating voltage measurement across R_d .

IV. COMMON SOURCE JFET AMPLIFIER

Calculate the required $-V_{gg}$, necessary to set $I_D = I_{DSS}/2$. Find R_d needed to produce $v_{DS} = 10$ V at this particular I_D and construct the common source amplifier circuit in Figure 3.

Recommended Procedure: Setting the quiescent DC bias drain current, I_D , to half of I_{DSS} provides for the largest possible symmetrical output current swing. Placing the corresponding DC V_{ds} at $2/3$ Of V_{dd} puts the JFET comfortably into the saturation region. Therefore, choosing the nearest standard fixed-value 5% resistor will be sufficient to use for R_d . Set $-V_{gg}$ and V_{dd} to their nominally correct values using the two independent variable DC bench supplies before connecting them to the circuit.

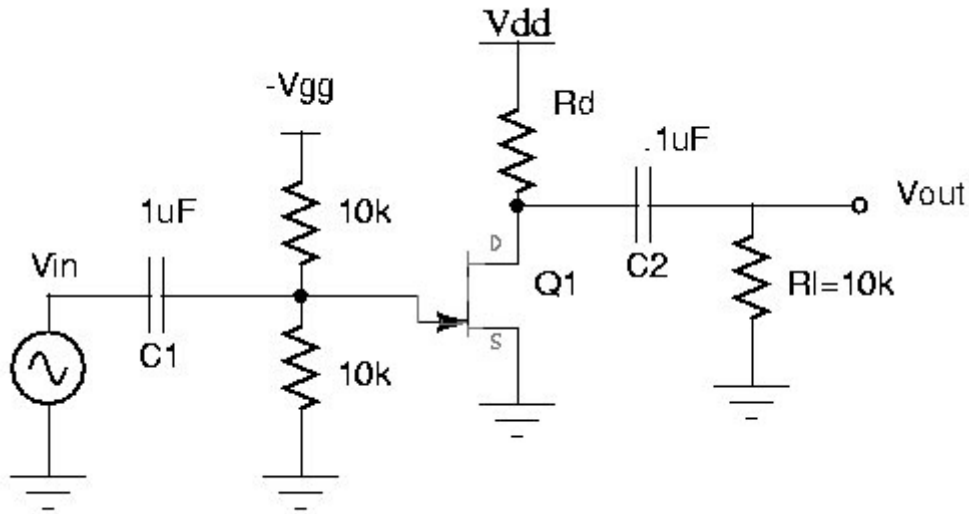

Figure 3. Common Source JFET Amplifier.

NOTE: Re-draw all schematics in your engineering notes and make any experimentw scribbles or annotations there.

Measure DC operating quantities. Determine the small-signal gain $A_V = V_{OUT}/V_{IN}$ and transconductance g_m , over a range which the amplifier does not distort using a 10 kHz. sine wave input signal. Determine whether the circuit inverts and explain why it appears as it does. Provide a plot of gain vs. input level and signal distortion.

Recommended Procedure: The necessary DC quantities are actual V_{gg} , V_{dd} , V_{GS} , V_{DS} and I_D (found from ohm's law). Use an oscilloscope to view both the input and output signals to note when the output becomes distorted by superimposing the AC and DC signals on top of the other and visually comparing the waveshapes. As the amplifier becomes non-linear, the output sine wave will begin to significantly distort. Take V_{OUT} and V_{IN} , ac RMS measurements using a DVM. In your report, plot the voltage gain, A_V vs. input amplitude (all ac RMS) and note where the output is distorted. Since the amplifier is small signal, we would expect distortion to begin appearing when V_{IN} exceeds 1-2 V peak. From this plot, determine the best estimate of A_V and calculate g_m accordingly and compare to the theoretically expected value.