

CS 277: Database System Implementation

Notes 6: Query Processing

Arthur Keller

CS 277 - Spring 2002

Notes 6

1

Query Processing

Q → Query Plan

Focus: Relational System

- Others?

CS 277 - Spring 2002

Notes 6

2

Example

Select B,D
From R,S
Where R.A = "c" ∧ S.E = 2 ∧ R.C=S.C

CS 277 - Spring 2002

Notes 6

3

R	A	B	C	S	C	D	E
a	1	10	10	x	2		
b	1	20	20	y	2		
c	2	10	30	z	2		
d	2	35	40	x	1		
e	3	45	50	y	3		

Answer

B	D
2	x

CS 277 - Spring 2002

Notes 6

4

- How do we execute query?

One idea

- Do Cartesian product
- Select tuples
- Do projection

CS 277 - Spring 2002

Notes 6

5

RXS	R.A	R.B	R.C	S.C	S.D	S.E
a	1	10	10	x	2	
a	1	10	20	y	2	
⋮						
⋮						
Bingo!	C	2	10	10	x	2
Got one...	⋮					
⋮						

CS 277 - Spring 2002

Notes 6

6

Relational Algebra - can be used to describe plans...

Ex: Plan I

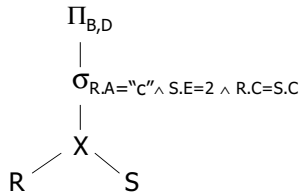

OR: $\Pi_{B,D} [\sigma_{R.A='c' \wedge S.E=2 \wedge R.C=S.C} (RXS)]$

Another idea:

Plan II

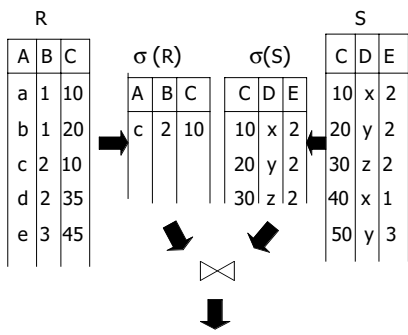
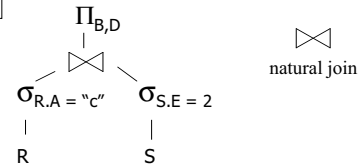

Plan III

Use R.A and S.C Indexes

- (1) Use R.A index to select R tuples with R.A = "c"
- (2) For each R.C value found, use S.C index to find matching tuples
- (3) Eliminate S tuples S.E \neq 2
- (4) Join matching R,S tuples, project B,D attributes and place in result

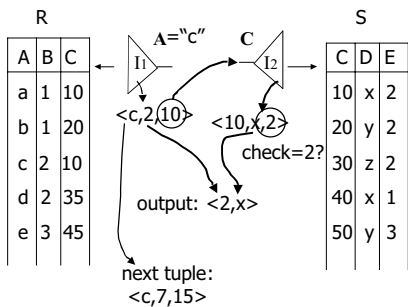

Overview of Query Optimization

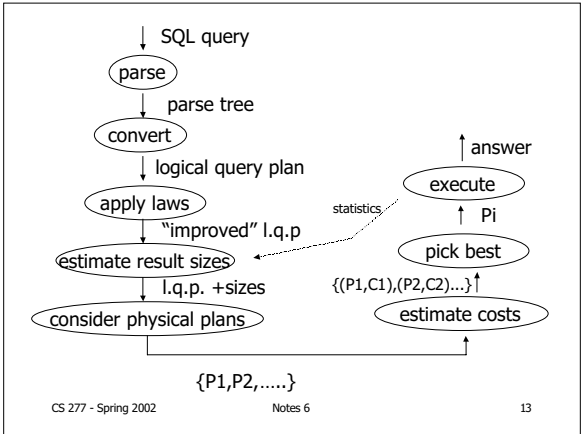

Example: SQL query

```

SELECT title
FROM StarsIn
WHERE starName IN (
  SELECT name
  FROM MovieStar
  WHERE birthdate LIKE '%1960'
);

```

(Find the movies with stars born in 1960)

CS 277 - Spring 2002 Notes 6 14

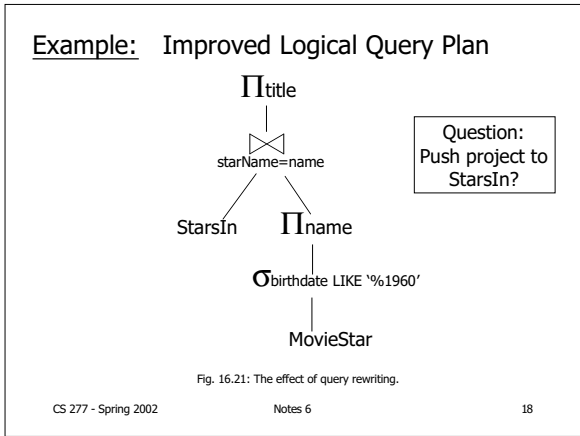
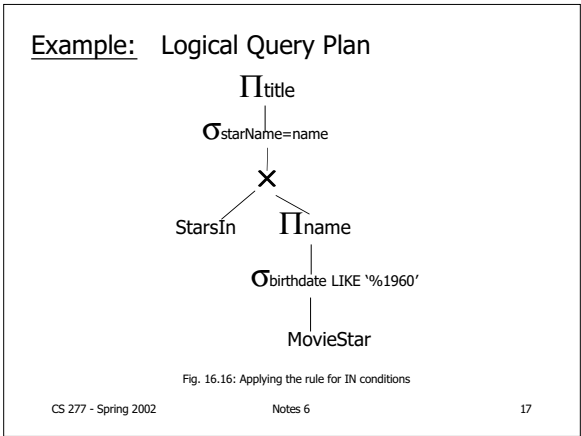
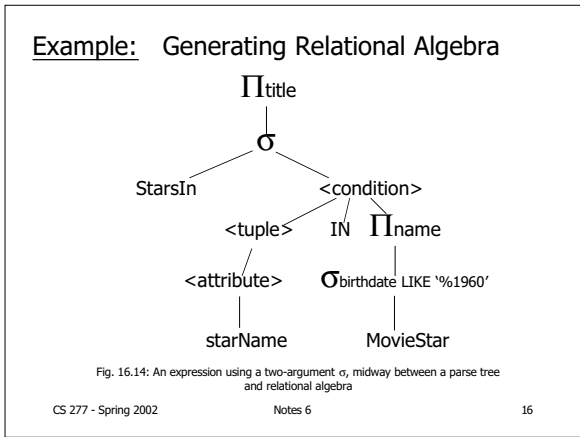
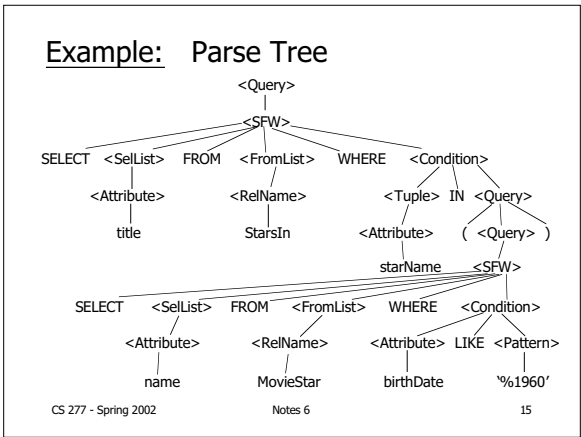

Example: Estimate Result Sizes

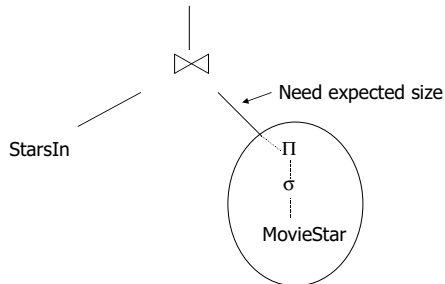

CS 277 - Spring 2002

Notes 6

19

Example: One Physical Plan

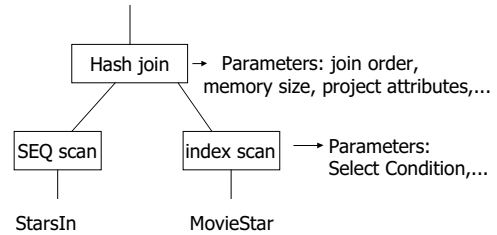

CS 277 - Spring 2002

Notes 6

20

Example: Estimate costs

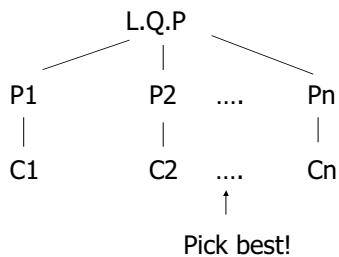

CS 277 - Spring 2002

Notes 6

21

Textbook outline

Chapter 15

15.1 Physical operators

- Scan, sort, ...

15.2-15.9 Implementing operators + estimating their cost

CS 277 - Spring 2002

Notes 6

22

Chapter 16

16.1 Parsing

16.2 Algebraic laws

16.3 Parse tree -> logical query plan

16.4 Estimating result sizes

16.5-16.7 Cost based optimization

CS 277 - Spring 2002

Notes 6

23

Reading textbook - Chapters 15,16

Optional: 15.7-15.9, 16.6-16.7

Optional: Duplicate elimination operator
grouping, aggregation operators

CS 277 - Spring 2002

Notes 6

24

Query Optimization - In class order

- Relational algebra level
- Detailed query plan level
 - Estimate Costs
 - without indexes
 - with indexes
 - Generate and compare plans

CS 277 - Spring 2002

Notes 6

25

Relational algebra optimization

- Transformation rules (preserve equivalence)
- What are good transformations?

CS 277 - Spring 2002

Notes 6

26

Rules: Natural joins & cross products & union

$$R \bowtie S = S \bowtie R$$
$$(R \bowtie S) \bowtie T = R \bowtie (S \bowtie T)$$

CS 277 - Spring 2002

Notes 6

27

Note:

- Carry attribute names in results, so order is not important
- Can also write as trees, e.g.:

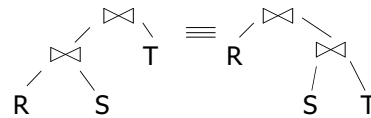

CS 277 - Spring 2002

Notes 6

28

Rules: Natural joins & cross products & union

$$R \bowtie S = S \bowtie R$$
$$(R \bowtie S) \bowtie T = R \bowtie (S \bowtie T)$$

$$R \times S = S \times R$$
$$(R \times S) \times T = R \times (S \times T)$$

$$R \cup S = S \cup R$$
$$R \cup (S \cup T) = (R \cup S) \cup T$$

CS 277 - Spring 2002

Notes 6

29

Rules: Selects

$$\sigma_{p1 \wedge p2}(R) = \sigma_{p1} [\sigma_{p2}(R)]$$

$$\sigma_{p1 \vee p2}(R) = [\sigma_{p1}(R)] \cup [\sigma_{p2}(R)]$$

CS 277 - Spring 2002

Notes 6

30

Bags vs. Sets

R = {a,a,b,b,b,c}

S = {b,b,c,c,d}

RUS = ?

- Option 1 SUM

RUS = {a,a,b,b,b,b,b,c,c,c,d}

- Option 2 MAX

RUS = {a,a,b,b,b,c,c,d}

Option 2 (MAX) makes this rule work:

$$\sigma_{p_1 \vee p_2}(R) = \sigma_{p_1}(R) \cup \sigma_{p_2}(R)$$

Example: R={a,a,b,b,b,c}

P1 satisfied by a,b; P2 satisfied by b,c

$$\sigma_{p_1 \vee p_2}(R) = \{a,a,b,b,b,c\}$$

$$\sigma_{p_1}(R) = \{a,a,b,b,b\}$$

$$\sigma_{p_2}(R) = \{b,b,b,c\}$$

$$\sigma_{p_1}(R) \cup \sigma_{p_2}(R) = \{a,a,b,b,b,c\}$$

"Sum" option makes more sense:

Senators (.....)

Rep (.....)

T1 = $\pi_{yr,state}$ Senators; T2 = $\pi_{yr,state}$ Reps

T1	Yr	State	T2	Yr	State
	97	CA		99	CA
	99	CA		99	CA
	98	AZ		98	CA

Union?

Executive Decision

-> Use "SUM" option for bag unions

-> Some rules cannot be used for bags

Rules: Project

Let: X = set of attributes

Y = set of attributes

XY = X U Y

~~$$\pi_{xy}(R) = \pi_x[\pi_y(R)]$$~~

Rules: $\sigma + \bowtie$ combined

Let p = predicate with only R attribs

q = predicate with only S attribs

m = predicate with only R,S attribs

$$\sigma_p(R \bowtie S) = [\sigma_p(R)] \bowtie S$$

$$\sigma_q(R \bowtie S) = R \bowtie [\sigma_q(S)]$$

Rules: $\sigma + \bowtie$ combined (continued)

Some Rules can be Derived:

$$\sigma_{p \wedge q} (R \bowtie S) =$$

$$\sigma_{p \wedge q \wedge m} (R \bowtie S) =$$

$$\sigma_{p \vee q} (R \bowtie S) =$$

CS 277 - Spring 2002

Notes 6

37

Do one:

$$\sigma_{p \wedge q} (R \bowtie S) = [\sigma_p (R)] \bowtie [\sigma_q (S)]$$

$$\sigma_{p \wedge q \wedge m} (R \bowtie S) = \sigma_m [(\sigma_p R) \bowtie (\sigma_q S)]$$

$$\sigma_{p \vee q} (R \bowtie S) = [(\sigma_p R) \bowtie S] \cup [R \bowtie (\sigma_q S)]$$

CS 277 - Spring 2002

Notes 6

38

--> Derivation for first one:

$$\sigma_{p \wedge q} (R \bowtie S) =$$

$$\sigma_p [\sigma_q (R \bowtie S)] =$$

$$\sigma_p [R \bowtie \sigma_q (S)] =$$

$$[\sigma_p (R)] \bowtie [\sigma_q (S)]$$

CS 277 - Spring 2002

Notes 6

39

Rules: π, σ combined

Let x = subset of R attributes

z = attributes in predicate P
(subset of R attributes)

$$\pi_x [\sigma_p (R)] = \pi_x \{ \sigma_p [\overset{\pi_{xz}}{\pi_x} (R)] \}$$

CS 277 - Spring 2002

Notes 6

40

Rules: π, \bowtie combined

Let x = subset of R attributes

y = subset of S attributes

z = intersection of R,S attributes

$$\pi_{xy} (R \bowtie S) =$$

$$\pi_{xy} \{ [\pi_{xz} (R)] \bowtie [\pi_{yz} (S)] \}$$

CS 277 - Spring 2002

Notes 6

41

$$\pi_{xy} \{ \sigma_p (R \bowtie S) \} =$$

$$\pi_{xy} \{ \sigma_p [\pi_{xz'} (R) \bowtie \pi_{yz'} (S)] \}$$

$$z' = z \cup \{ \text{attributes used in P} \}$$

CS 277 - Spring 2002

Notes 6

42

Rules for σ, π combined with X

similar...

e.g., $\sigma_p(R \bowtie S) = ?$

Rules σ, U combined:

$$\sigma_p(R \cup S) = \sigma_p(R) \cup \sigma_p(S)$$

$$\sigma_p(R - S) = \sigma_p(R) - S = \sigma_p(R) - \sigma_p(S)$$

Which are "good" transformations?

- $\sigma_{p1 \wedge p2}(R) \rightarrow \sigma_{p1}[\sigma_{p2}(R)]$
- $\sigma_p(R \bowtie S) \rightarrow [\sigma_p(R)] \bowtie S$
- $R \bowtie S \rightarrow S \bowtie R$
- $\pi_x[\sigma_p(R)] \rightarrow \pi_x\{\sigma_p[\pi_{xz}(R)]\}$

Conventional wisdom:
do projections early

Example: $R(A,B,C,D,E)$ $x=\{E\}$
 $P: (A=3) \wedge (B="cat")$

$$\pi_x\{\sigma_p(R)\} \text{ vs. } \pi_E\{\sigma_p\{\pi_{ABE}(R)\}\}$$

But What if we have A, B indexes?

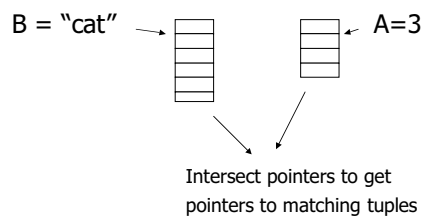

Bottom line:

- No transformation is always good
- Usually good: early selections

In textbook: more transformations

- Eliminate common sub-expressions
- Other operations: duplicate elimination

CS 277 - Spring 2002

Notes 6

49

Outline - Query Processing

- Relational algebra level
 - transformations
 - good transformations
- Detailed query plan level
 - estimate costs
 - generate and compare plans

CS 277 - Spring 2002

Notes 6

50

- Estimating cost of query plan

- (1) Estimating size of results
- (2) Estimating # of IOs

CS 277 - Spring 2002

Notes 6

51

Estimating result size

- Keep statistics for relation R
 - $T(R)$: # tuples in R
 - $S(R)$: # of bytes in each R tuple
 - $B(R)$: # of blocks to hold all R tuples
 - $V(R, A)$: # distinct values in R for attribute A

CS 277 - Spring 2002

Notes 6

52

Example

R	A	B	C	D
cat	1	10	a	
cat	1	20	b	
dog	1	30	a	
dog	1	40	c	
bat	1	50	d	

A: 20 byte string

B: 4 byte integer

C: 8 byte date

D: 5 byte string

$$T(R) = 5 \quad S(R) = 37$$

$$V(R, A) = 3 \quad V(R, C) = 5$$

$$V(R, B) = 1 \quad V(R, D) = 4$$

CS 277 - Spring 2002

Notes 6

53

Size estimates for $W = R1 \times R2$

$$T(W) = T(R1) \times T(R2)$$

$$S(W) = S(R1) + S(R2)$$

CS 277 - Spring 2002

Notes 6

54

Size estimate for $W = \sigma_{A=a}(R)$

$$S(W) = S(R)$$

$$T(W) = ?$$

Example

R	A	B	C	D
cat	1	10	a	
cat	1	20	b	
dog	1	30	a	
dog	1	40	c	
bat	1	50	d	

$$V(R,A)=3$$

$$V(R,B)=1$$

$$V(R,C)=5$$

$$V(R,D)=4$$

$$W = \sigma_{z=val}(R) \quad T(W) = \frac{T(R)}{V(R,Z)}$$

Assumption:

Values in select expression $Z = val$ are uniformly distributed over possible $V(R,Z)$ values.

Alternate Assumption:

Values in select expression $Z = val$ are uniformly distributed over domain with $DOM(R,Z)$ values.

Example

R	A	B	C	D
cat	1	10	a	
cat	1	20	b	
dog	1	30	a	
dog	1	40	c	
bat	1	50	d	

Alternate assumption
 $V(R,A)=3 \quad DOM(R,A)=10$
 $V(R,B)=1 \quad DOM(R,B)=10$
 $V(R,C)=5 \quad DOM(R,C)=10$
 $V(R,D)=4 \quad DOM(R,D)=10$

$$W = \sigma_{z=val}(R) \quad T(W) = ?$$

$$C=val \Rightarrow T(W) = (1/10)1 + (1/10)1 + \dots = (5/10) = 0.5$$

$$B=val \Rightarrow T(W) = (1/10)5 + 0 + 0 = 0.5$$

$$A=val \Rightarrow T(W) = (1/10)2 + (1/10)2 + (1/10)1 = 0.5$$

Example

R

A	B	C	D
cat	1	10	a
cat	1	20	b
dog	1	30	a
dog	1	40	c
bat	1	50	d

Alternate assumption
 $V(R,A)=3$ $DOM(R,A)=10$
 $V(R,B)=1$ $DOM(R,B)=10$
 $V(R,C)=5$ $DOM(R,C)=10$
 $V(R,D)=4$ $DOM(R,D)=10$

$$W = \sigma_{z=val}(R) \quad T(W) = \frac{T(R)}{DOM(R,Z)}$$

Selection cardinality

$SC(R,A)$ = average # records that satisfy equality condition on R.A

$$SC(R,A) = \begin{cases} \frac{T(R)}{V(R,A)} \\ \frac{T(R)}{DOM(R,A)} \end{cases}$$

What about $W = \sigma_{z \geq val}(R)$?

$$T(W) = ?$$

- Solution # 1:

$$T(W) = T(R)/2$$

- Solution # 2:

$$T(W) = T(R)/3$$

- Solution # 3: Estimate values in range

Example R

	Z

Min=1 $V(R,Z)=10$
 $W = \sigma_{z \geq 15}(R)$
 Max=20

$$f = \frac{20-15+1}{20-1+1} = \frac{6}{20} \quad (\text{fraction of range})$$

$$T(W) = f \times T(R)$$

Equivalently:

$f \times V(R,Z)$ = fraction of distinct values

$$T(W) = \frac{[f \times V(Z,R)] \times T(R)}{V(Z,R)} = f \times T(R)$$

Size estimate for $W = R1 \bowtie R2$

Let x = attributes of R1

y = attributes of R2

Case 1

$$X \cap Y = \emptyset$$

Same as $R1 \times R2$

Case 2 $W = R1 \bowtie R2$ $X \cap Y = A$

R1	A	B	C

R2	A	D

Assumption:
 $V(R1,A) \leq V(R2,A) \Rightarrow$ Every A value in R1 is in R2
 $V(R2,A) \leq V(R1,A) \Rightarrow$ Every A value in R2 is in R1

"containment of value sets" Sec. 7.4.4

CS 277 - Spring 2002 Notes 6 67

Computing $T(W)$ when $V(R1,A) \leq V(R2,A)$

R1	A	B	C

R2	A	D

Take 1 tuple from R1. An oval highlights a row in R1, with an arrow labeled "Match" pointing to the A column in R2.

1 tuple matches with $\frac{T(R2)}{V(R2,A)}$ tuples...

so $T(W) = \frac{T(R2)}{V(R2,A)} \times T(R1)$

CS 277 - Spring 2002 Notes 6 68

- $V(R1,A) \leq V(R2,A)$ $T(W) = \frac{T(R2) T(R1)}{V(R2,A)}$
- $V(R2,A) \leq V(R1,A)$ $T(W) = \frac{T(R2) T(R1)}{V(R1,A)}$

[A is common attribute]

CS 277 - Spring 2002 Notes 6 69

In general $W = R1 \bowtie R2$

$$T(W) = \frac{T(R2) T(R1)}{\max\{ V(R1,A), V(R2,A) \}}$$

CS 277 - Spring 2002 Notes 6 70

Case 2 with alternate assumption

Values uniformly distributed over domain

R1	A	B	C

R2	A	D

This tuple matches $T(R2)/\text{DOM}(R2,A)$ so

$$T(W) = \frac{T(R2) T(R1)}{\text{DOM}(R2, A)} = \frac{T(R2) T(R1)}{\text{DOM}(R1, A)}$$

Assume the same

CS 277 - Spring 2002 Notes 6 71

In all cases:

$$S(W) = S(R1) + S(R2) - S(A)$$

size of attribute A

CS 277 - Spring 2002 Notes 6 72

Using similar ideas,
we can estimate sizes of:

$\Pi_{AB}(R)$ Sec. 16.4.2

$\sigma_{A=a \wedge B=b}(R)$ Sec. 16.4.3

$R \bowtie S$ with common attribs. A,B,C
Sec. 16.4.5

Union, intersection, diff, Sec. 16.4.7

CS 277 - Spring 2002

Notes 6

73

Note: for complex expressions, need
intermediate T,S,V results.

E.g. $W = [\sigma_{A=a}(R1)] \bowtie R2$

Treat as relation U

$T(U) = T(R1)/V(R1,A)$ $S(U) = S(R1)$

Also need $V(U, *)$!!

CS 277 - Spring 2002

Notes 6

74

To estimate Vs

E.g., $U = \sigma_{A=a}(R1)$

Say R1 has attribs A,B,C,D

$V(U, A) =$

$V(U, B) =$

$V(U, C) =$

$V(U, D) =$

CS 277 - Spring 2002

Notes 6

75

Example

R1	A	B	C	D
cat	1	10	10	
cat	1	20	20	
dog	1	30	10	
dog	1	40	30	
bat	1	50	10	

$V(R1,A)=3$

$V(R1,B)=1$

$V(R1,C)=5$

$V(R1,D)=3$

$U = \sigma_{A=a}(R1)$

$V(U,A) = 1$ $V(U,B) = 1$ $V(U,C) = \frac{T(R1)}{V(R1,A)}$

$V(D,U)$... somewhere in between

CS 277 - Spring 2002

Notes 6

76

Possible Guess $U = \sigma_{A=a}(R)$

$V(U,A) = 1$

$V(U,B) = V(R,B)$

CS 277 - Spring 2002

Notes 6

77

For Joins $U = R1(A,B) \bowtie R2(A,C)$

$V(U,A) = \min \{ V(R1, A), V(R2, A) \}$

$V(U,B) = V(R1, B)$

$V(U,C) = V(R2, C)$

[called "preservation of value sets" in
section 16.4.4]

CS 277 - Spring 2002

Notes 6

78

Example:

$$Z = R1(A,B) \bowtie R2(B,C) \bowtie R3(C,D)$$

$$\boxed{R1} \quad T(R1) = 1000 \quad V(R1,A)=50 \quad V(R1,B)=100$$

$$\boxed{R2} \quad T(R2) = 2000 \quad V(R2,B)=200 \quad V(R2,C)=300$$

$$\boxed{R3} \quad T(R3) = 3000 \quad V(R3,C)=90 \quad V(R3,D)=500$$

CS 277 - Spring 2002

Notes 6

79

$$\text{Partial Result: } U = R \bowtie S$$

$$T(U) = \frac{1000 \times 2000}{200} \quad V(U,A) = 50$$

$$V(U,B) = 100$$

$$V(U,C) = 300$$

CS 277 - Spring 2002

Notes 6

80

$$Z = U \bowtie R3$$

$$T(Z) = \frac{1000 \times 2000 \times 3000}{200 \times 300} \quad V(Z,A) = 50$$

$$V(Z,B) = 100$$

$$V(Z,C) = 90$$

$$V(Z,D) = 500$$

CS 277 - Spring 2002

Notes 6

81

Summary

- Estimating size of results is an "art"
- Don't forget:
Statistics must be kept up to date...
(cost?)

CS 277 - Spring 2002

Notes 6

82

Outline

- Estimating cost of query plan
 - Estimating size of results ← done!
 - Estimating # of IOs ← next...
- Generate and compare plans

CS 277 - Spring 2002

Notes 6

83