



LABORATORY ASSIGNMENT NUMBER 1 FOR CMPE 118/218

Due by 6:00pm on Wednesday, January 21, 2008

Pre-Lab Due by **12:00 noon** on Thursday, January 15, 2008

Purpose:

This lab is intended to acquaint you with the behavior of operational amplifiers and comparators. In addition, you will gain experience using the proto-board to try out circuits and to build physical circuits from a schematic. Lastly, you will prototype a sensor circuit that you will use extensively in your final projects.

Minimum Parts Required:

1 CMPE118L Student Lab Kit, using at least 1 each: LM555, Visible LED, IR LED, photo transistor, LM339 & LM324. A photodarlington from the TA's. Assorted resistors and capacitors. See the BELS for any parts you need that are not in the parts kit.

References:

The library has several of the publications listed in the Horowitz & Hill appendix. Take some time to become familiar with them. The articles and advertisements will begin to make more sense to you as the quarter progresses. The articles, and often the advertisements, are very good information sources. Make sure you have read H&H Ch. 5 – 5.09 and CKO Ch. 12.

Pre-Lab – Part A:

Complete the following exercises AFTER you have read through the lab assignment and BEFORE coming into the 118 Lab to complete the lab.

A.1) What are the values of resistors with the following color codes:

- a) red red red
- b) brown black red
- c) yellow violet orange
- d) brown black green
- e) brown black black
- f) green black yellow

A.2) Draw a schematic (using Cadence Schematic capture, part of OrCAD) of the configuration you will use for Question 4.2.

A.3) Draw a schematic (using Cadence Schematic capture, part of OrCAD) of the configuration you will use for Question 4.

A.4) What should you never, ever, insert into the proto board holes (be tame)?

In the report:

Include your answers to the exercises in the Pre-Lab.

Building Circuits in the Lab

Reading:

Horowitz & Hill Appendices C, D, E, I, and J. (and if you are unfamiliar with an oscilloscope, Appendix A). Chapter 5 up to 5.10. CKO Ch. 12.

Background:

Component identification:

Appendices C and D in Horowitz & Hill cover the resistor color code and standard values. The 555 in

your kit may be labeled LM555, NE555 or several other variations. The 555 is the important part.

The tantalum capacitors are the ones that look like little gumdrops. Pay attention to the polarity markings. **DO NOT REVERSE THE POLARITY.** See note below.

The electrolytic capacitors look like little cylinders. Both leads may come out of one end of the capacitor (radial lead), or the leads may come out of opposite ends of the capacitor (axial lead).

Both tantalum and electrolytic capacitors are almost universally marked in their value in micro-Farads (μF). Often the μF indicator will also be present.

The ceramic disk capacitors are marked for size in a number of different ways. The most common are:

22 or 22K

This indicates 22 pico-Farads. For these capacitors a small number is almost always the value in pF. The letter is used to indicate a usable temperature range. The exception are caps marked:

103 or 104

These are most likely $.01\mu\text{F}$ and $.1\mu\text{F}$ respectively. In this case the markings are similar to resistor codes. The first 2 digits represent the value and the last digit the power of 10 multiplier. The resulting number is the number of pF. In the example above we have $10 * 10^3 \text{ pF}$ ($1e4 * 1e-12 = 1e-8 = .01\mu\text{F}$).

Note: Polarized, tantalum and electrolytic capacitors are marked for the proper polarity. This polarity is **VERY** important! If inserted incorrectly tantalum capacitors have been known to self-destruct **EXPLOSIVELY!!** At the very least reversing the polarity can look like a short to the power supply and prevent anything else in your circuit from working. Examine polarized caps very carefully before inserting. Some mark the positive lead, and some mark the negative lead. Be sure which type you have before you wire it into your circuit.

Pin Identification:

Below is a typical chip drawing. For purposes of determining the pin numbering, note the relative positions of:

- 1) a dot near one of the pins,
- 2) or alternatively a semi-circular depression at one end of the chip.

Once you have found either of these markings, the pin numbers proceed around the chip counterclockwise (assuming that you are looking at the top of the chip with the depression or dot at the top). The highest numbered pin is always opposite pin 1.

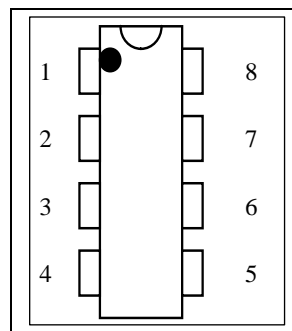

Prototyping Board (PROTO-BOARD):

You will be building the circuits for this lab using a solderless breadboard that we refer to as a proto-board. Below is a diagram of the types of connections on the proto-board.

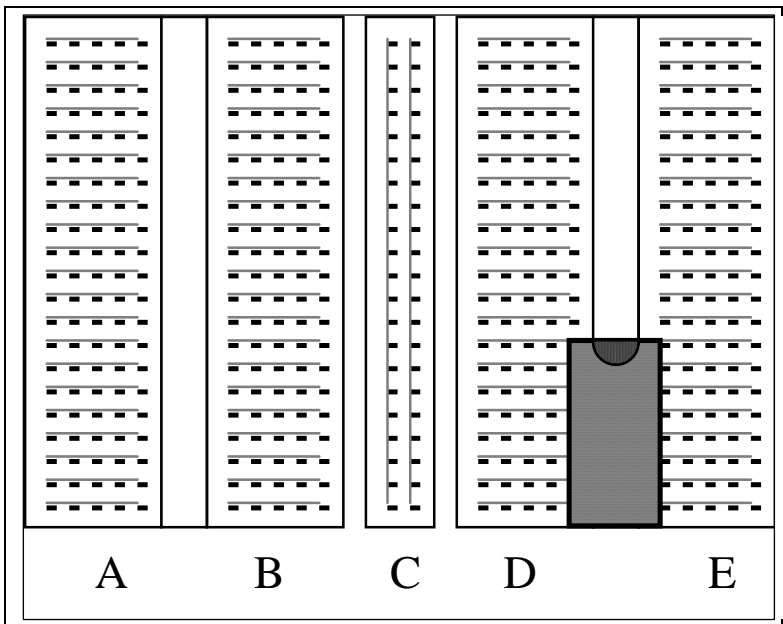

Regions labeled A, B, D, E are the normal hook-up areas. As indicated by the gray lines, horizontal groups of these connections are internally tied together. When a chip is plugged into the board as shown, these strips give you 4 connections to each of the IC pins. The connections in region C are intended as the power and ground busses. Again as indicated by the gray lines, they are tied together vertically. Note, on some proto-boards the connections in region C are broken in the center, leaving 4 vertical strings. Check your board, you may want to jumper these to yield 2 vertical sections, good for distributing power & ground.

Take the time to make your circuits neat and tidy, with wires low over the board. It will only take a few minutes longer to do so, and it will make (the inevitable) debugging go very much quicker. Below is a figure from CKO about the right and wrong ways to put together a proto-board.

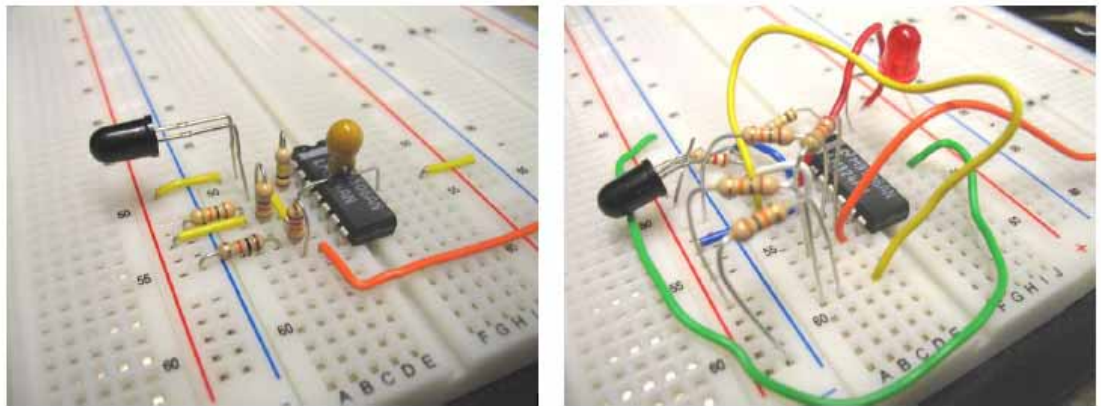

The proto-boards are fairly robust, however they are susceptible to damage from wires that are too large. Do not use hook-up wire larger than 24 gauge. This should not be a problem, since we are supplying hook-up wire kits. The other thing to watch for is component lead sizes. This will not be much of a problem during the labs, but you should be aware of these limitations since in later quarters you may use these boards to prototype your own circuits.

DO NOT INSERT 'SCOPE PROBE TIPS INTO THE PROTO-BOARD!

Assignment

Nothing, this part is all background.

Part 1: Building a Signal Source

Reading:

The attached article on the 555.

Background:

A source of a repetitive signal is often a nice thing to have. Here you will use an LM555 to generate the drive signals to LEDs that you will use as the signal source in later parts of the lab.

Assignment:

Complete the following exercises.



- 1.1) Build up the circuit shown below. The IR LED should be the clear one. Its anode is the long lead.

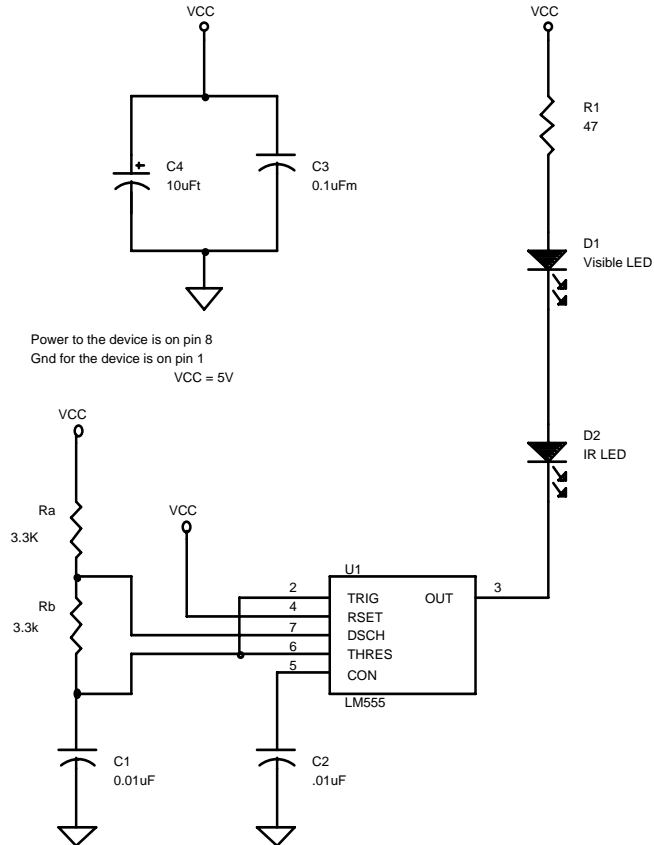

Figure 3.1



- 1.2) Examine the output on pin 3. Using one of the 'scope face templates, draw a picture of the waveform. Be sure to label the axes according to the 'scope settings.

In the report:

The drawing completed in Part 1.2. All wiring diagrams and schematics should be completed using the Orcad Schematic Capture program provided on each workstation.

Part 2: The Photo-Transistor

Reading:

Horowitz & Hill section 15.02, CKO Ch. 11 (section on light sensors).

Assignment:

Complete the Following exercises.



- 2.1) Hook up the photo transistor in a sourcing configuration (collector to +5V) with a 100k load resistor to ground. The photo transistor should be placed on the opposite end of the proto-board from the IR LED (along long axis). Aim the photo transistor at the IR LED (the sensitive region, and the emitter of the LED are opposite the leads). You get power & ground from the bench-top power supplies, plugged into the power and ground rails of the protoboard.



- 2.2) Draw a schematic of the configuration in 2.1.



- 2.3) Using the Oscilloscope, look at the output of the photo transistor. Make a 'scope face drawing of what you see.

- 2.4) Hook up the photo transistor in a sinking configuration (emitter to ground) with a 100k load resistor to power. The photo transistor should be placed on the opposite end of the protoboard from the IR LED (along long axis). Aim the photo transistor at the IR LED (the sensitive region, and the emitter of the LED are opposite the leads).
- 2.5) Draw a schematic of the configuration in 2.4.
- 2.6) Using the Oscilloscope, look at the output of the photo transistor. Make a 'scope face drawing of what you see.
- 2.7) Explain the differences between the drawings for parts 2.3 & 2.6.
- 2.8) Replace the 100k load resistor with a 1k load resistor and return the circuit to the sourcing configuration.
- 2.9) What is the impact on the output of the photo transistor?

In the report:

The 'scope face drawings from 2.3 & 2.6, the schematics from 2.2 & 2.5 as well as the answers to the questions in 2.7 & 2.9

Part 3: Op-Amps**Reading:**

Horowitz & Hill sections 4.01-4.09, CKO Ch. 10 and 12.

Assignment:

Complete the following exercises.

- 3.1) Draw a schematic of a trans-resistive configuration with a gain of 1V/mA. You should maintain 2.5V across the photo-transistor. The schematic should be complete with component values, based on the parts you have in your kits.
- 3.2) Build up that configuration on your proto-board.
- 3.3) Hook the output of the photo-transistor to the op-amp input. Make a 'scope face drawing of the op-amp output.
- 3.4) Using the oscilloscope, measure the output of the op-amp with the emitter 2" from the detector. What is the measured output?
- 3.5) Describe the oscilloscope settings you used to make the measurements in part 3.4. Why is the configuration you chose the best configuration for making this measurement?

In the report:

Include the schematic from 3.1, the drawing from 3.3, and the answers to questions in 3.4 & 3.5.

Part 4: Comparators**Reading:**

Horowitz & Hill section 4.24, CKO Ch. 10 and 12, the attached sheet on configuring comparators.

Assignment:

Complete the following exercises.

- 4.1) You should design a comparator in an inverting configuration with hysteresis. Shoot for trip points at approximately 0.8V and 1V.
- 4.2) Draw a schematic of the desired configuration, complete with component values..

- 4.3) Hook the output of the op-amp to the comparator input. You may need to adjust the gain of your op-amp circuit.
- 4.4) Using the oscilloscope in dual trace mode, observe the output of the op-amp and the output of the comparator. Make a 'scope face drawing of the two traces.

In the report: Include the schematic from 4.2, the drawing from 4.4.

Part 5: Filtering

Reading: Horowitz & Hill 5-5.09., CKO Ch. 12, Handout on Analog Filtering

Assignment: Complete the following exercise.

- 5.1) For the final project in this class, an infrared emitter is going to be used as a beacon to let you know when a target is active. The emitter is driven by a 555 oscillator and generates a 50% duty-cycle on/off wave at a frequency of 2 kHz. The amount of light into the input of a photosensor from the beacon is at least 0.05 mW/cm². The amount of background light is less than 0.01 mW/cm². In addition to this signal, there is background sunlight entering the sensor with intensity of no more than 0.1 mW/cm², and 120 Hz noise from the ceiling lights of no more than 0.03 mW/cm².

The photosensor is the Fairchild QSD733 photo-darlington (see class datasheets handout).

Design a circuit with this photosensor that produces an output logic "High" (Steady signal above 3.5V) when the sensor is pointed away from the beacon, and a logic "Low" when the sensor is positioned in front of the beacon (you may reverse this, but let us know why in your report). You may use any number of Ideal Op-Amps, power supply leads at 5V and Ground, and the resistor and capacitor values included in your lab kit (or standard values) in this design.

Make sure that your circuit includes an LED that lights up when in front of a beacon (this will be very important when you are debugging or working on your robot).

Note that if you are going to use the LM324, it only goes to 3.5V on a 5V rail, and your circuit should be tuned to give you a full swing when you detect the beacon.

- 5.2) Draw a schematic of the desired configuration, complete with component values.
- 5.3) Prototype your circuit, incrementally testing along the way (this is **VERY** important).
- 5.4) Using the 'scope, trace out the response of your filter to the beacon target at various distances (6", 1,2,5,10 ft). Try this with lights on, lights off, shades drawn, etc. Test your design. Do **NOT** dismantle your working prototype circuit; you will use this in the next lab.

In the report: Include the schematic from 5.2, the drawing from 5.4. Give an explanation of what you see, and how you might improve it. Bragging rights go to the team that can see the beacon from the farthest away without being blinded at close range (6").

Lab #1**Time Summary**

Be sure to turn this in with your lab report

This information is being gathered solely to produce statistical information to help improve the lab assignments.

Pre-Lab	Preparing Outside of the lab _____	In the lab working this part _____
Part 1	Preparing Outside of the lab _____	In the lab working this part _____
Part 2	Preparing Outside of the lab _____	In the lab working this part _____
Part 3	Preparing Outside of the lab _____	In the lab working this part _____
Part 4	Preparing Outside of the lab _____	In the lab working this part _____
Part 5	Preparing Outside of the lab _____	In the lab working this part _____
Report	Preparing the Lab Report _____	

Comparators

The basic configuration for an inverting comparator with hysteresis is the one shown below:

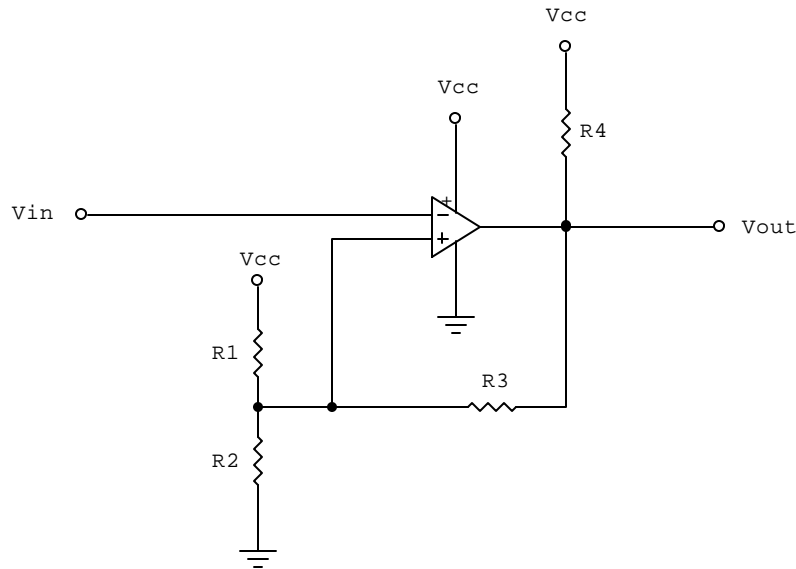

Configuring Comparators:

To calculate values for the resistors to achieve particular set points, follow the simplified procedure given below:

- 1) let the lower trip point = V_{a2}
- 2) let the upper trip point = V_{a1}
- 3) let the differences in the set points $V_{a1} - V_{a2} = \Delta V$
- 4) let $R_4 = 3.9K$
- 5) let $R_3 = 1M$
(these last two items are the simplifications from the general solution)
- 6) let $n = \Delta V / V_{a2}$
- 7) let $R_1 = nR_3$
- 8) solve for R_2 such that:

$$R_2 = \frac{R_1 \parallel R_3}{\frac{5}{V_{a1}} - 1}$$

The above assumes that the supply voltage is +5V.

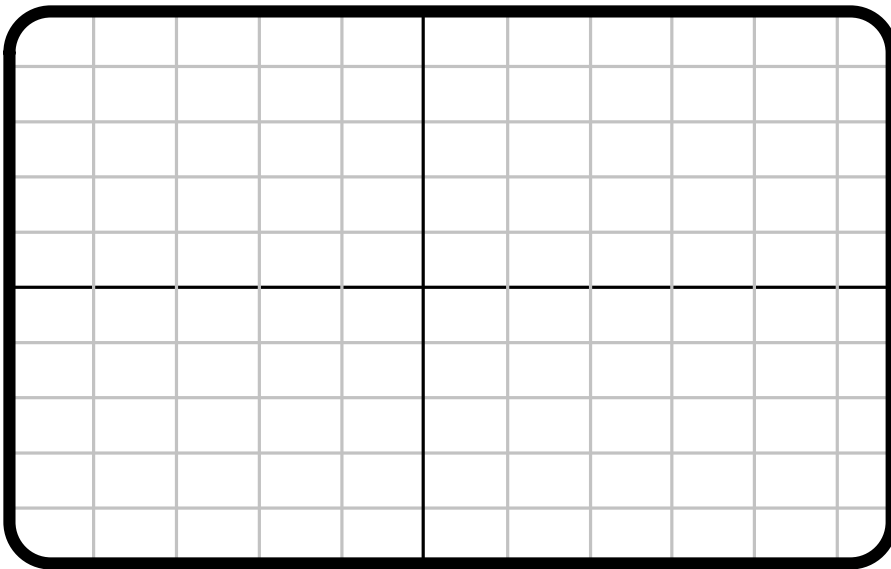

X Scale

Ch1 Scale

Ch. 2 Scale

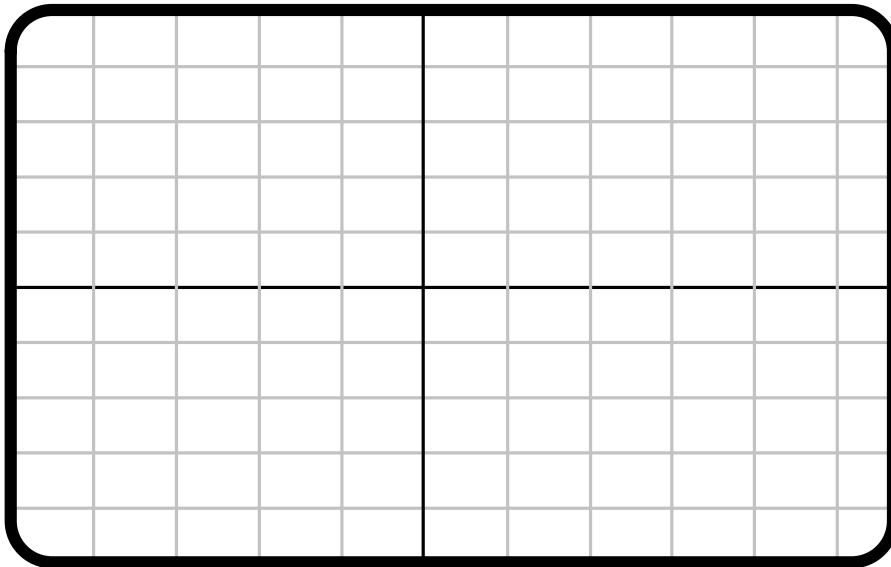

X Scale

Ch1 Scale

Ch. 2 Scale

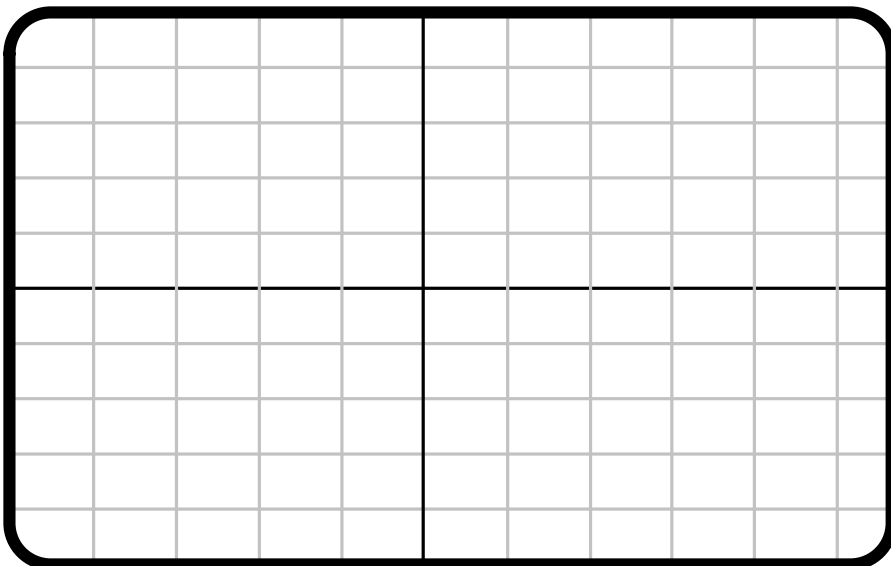

X Scale

Ch1 Scale

Ch. 2 Scale