

# The CMPE 118 A3982 2.0A Stepper Motor Module

Dept. of Computer Engineering, UCSC

## **Background:**

Allegro's A3982 is a complete microstepping motor driver with built-in translator for easy operation. It is designed to operate bipolar stepper motors in full-, half-, quarter-, and sixteenth-step modes, with an output drive capacity of up to 35 V and  $\pm 2$  A. The A3982 includes a fixed off-time current regulator which has the ability to operate in Slow or Mixed decay modes. It comes in 24-pin SOIC and TSSOP packages. Internal circuit protection includes thermal shutdown with hysteresis, undervoltage monitoring, and crossover current protection.

The CMPE118 A3982 Stepper Motor Module provides a convenient and robust interface for the A3982. Separate connectors provide access to the logic-level inputs, Stepper motor coil output connections, and the IC's power supply. This module makes use of a 7805 regulator for pull-ups and a TL7726QP clamp for protecting the digital inputs.

The data sheet for the A3982 translator and driver chip can be found on the Allegro.com website at: [http://www.allegromicro.com/en/Products/Part\\_Numbers/3982/3982.pdf](http://www.allegromicro.com/en/Products/Part_Numbers/3982/3982.pdf)

## **Using the CMPE118 A3982 2.0A Stepper Motor Module:**

In order to make use of the CMPE118 A3982 Stepper Motor Module, you will need to be familiar with the various connectors and their purposes. Since each connector has a single logical function (inputs, outputs, power supply, etc.) this is straightforward.

### **Logic-Level Inputs (J5):**

Access to the logic-level inputs of the A3982 is provided through J5. Enable, Direction, and STEP control for the stepper driver is specified through these connections.

There is no logic ground on this board to reduce noise. As such, care must be taken to provide a common ground back at the power supply or battery.

The pinout of J5 is as follows (all other pins are NO CONNECT):

| J5    | Connection |
|-------|------------|
| Pin 3 | Step       |
| Pin 4 | Direction  |
| Pin 5 | Enable     |

### **Full/Half-Step Connections (J3):**

The A3982 is capable of both full step (2 coils energized) or half-step (1-2 coils energized); this is set with the jumper J3. If it is OPEN, then the chip is set to FULL STEP mode. If a jumper is placed across the pins of J3, then the chip is set for HALF STEP mode.

### **Motor/Load Connections (J2):**

Connections to the coils of the stepper motor should be made through the screw-terminal connector located at J2. The pinout of J2 is as follows:

| J2            | Connection |
|---------------|------------|
| pin 1 & pin 2 | Phase A    |
| pin 3 & pin 4 | Phase B    |

**Power Supply and High-Current Ground Connector (J1):**

**J1, pin 1:** The A3982 requires a power supply for both the motors as well as its logic circuitry. Provisions for this are made through J1, pin 1, which includes a Schottky diode to provide reverse bias protection. A 7805 low drop-out, 100mA voltage regulator is provided on the Module PCB to clamp the digital inputs between -0.2V and 5.2V. The chip will operate between 8V (minimum) and 36V (maximum). This makes the A3982 Module much easier to use, since it includes its own voltage regulation and does not require an externally regulated +5V supply. Note that there is no ground connection between the input port (J5) and the power input (J1), for noise reasons. The source of the input signal should be connected back to ground at the power supply or batteries.

**A3982 Power Supply Requirements:**  $+8V < V_{in} (J1, \text{pin } 1) < +36V$

**J1, pin 2:** Since the module is capable of switching both coils on the stepper motor to 2.0A, care must be taken in the methods employed returning this substantial current to ground. For this reason, a separate high-current ground connection is available at J1, pin 2. A separate connection should be made between J3, pin 2 and the power supply or batteries. This will ensure that the logic power supply maintains a clean ground (the microcontroller must have a common ground to the power supply as well).

| J1    | Connection          |
|-------|---------------------|
| Pin 1 | Power (8V to 36V)   |
| Pin 2 | High Current Ground |

**CMPE118 A3982 2.0A Stepper Motor Module Schematic:**

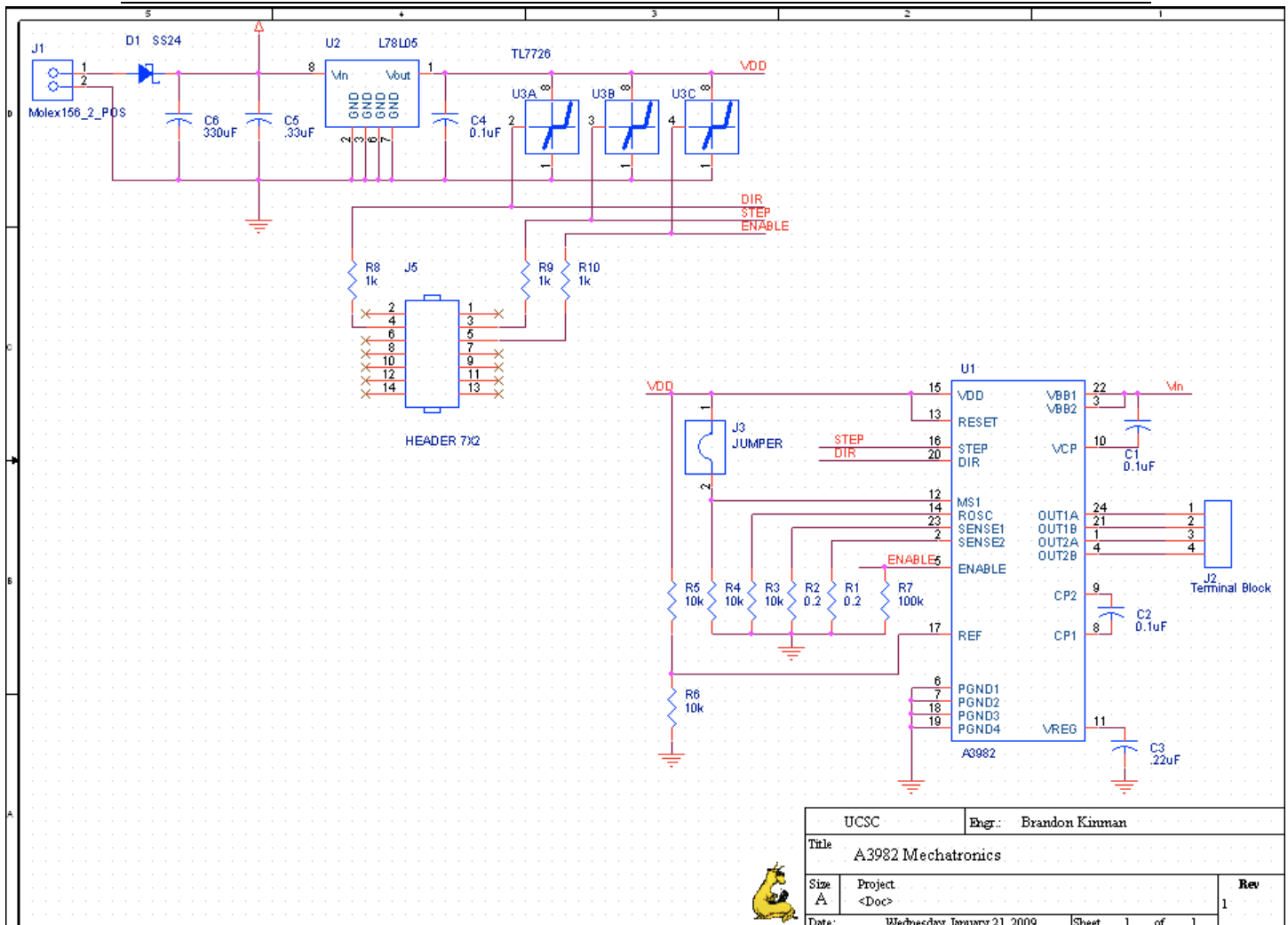

|                                   |                       |        |
|-----------------------------------|-----------------------|--------|
| UCSC                              | Engr.: Brandon Kinman |        |
| Title: A3982 Mechatronics         |                       |        |
| Size: A                           | Project: <Doc>        | Rev: 1 |
| Date: Wednesday, January 21, 2009 | Sheet: 1 of 1         |        |