

CMPE 117

Lectures:
Aperiodic Task Scheduling

© Luca de Alfaro, 2002-3

Scheduling Anomalies

• Theorem [Graham, 1976]:

If a task set is optimally scheduled on a multiprocessor with some priority assignment, fixed execution times, and precedence constraints, then the following can **increase** the schedule length:

- **increasing** the number of processors
- **reducing** execution times
- **weakening** the precedence relation

Scheduling: vocabulary

- a**: arrival time
- C**: computation time
- d**: deadline
- s**: starting time
- f**: finishing time
- $L = f - d$: lateness
- $E = \max(0, L)$: tardiness
- $X = d - a - C$: slack

Scheduling anomalies - example Adding one processor

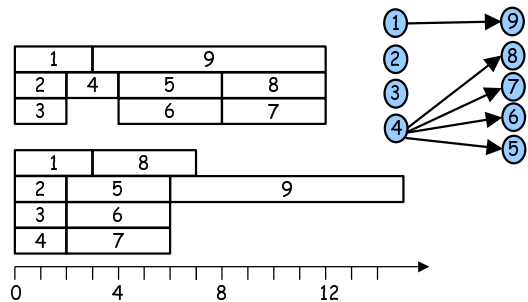

Scheduling: types

- Preemptive vs. non-preemptive.
- Synchronous (all processes arrive at once) or asynchronous (processes arrive one by one)
- Static (a , C , d of all processes known in advance) or on-line.
- Independent, or with dependency relation.
- Aperiodic vs. periodic vs. hybrid (mixed)

Scheduling anomalies - example Decreasing the running time by 1

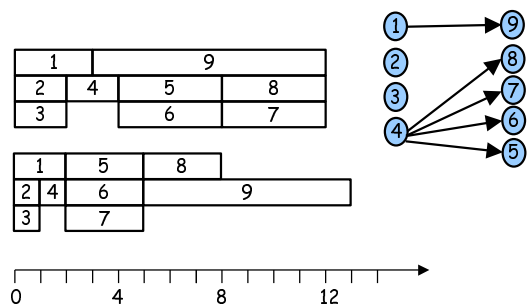

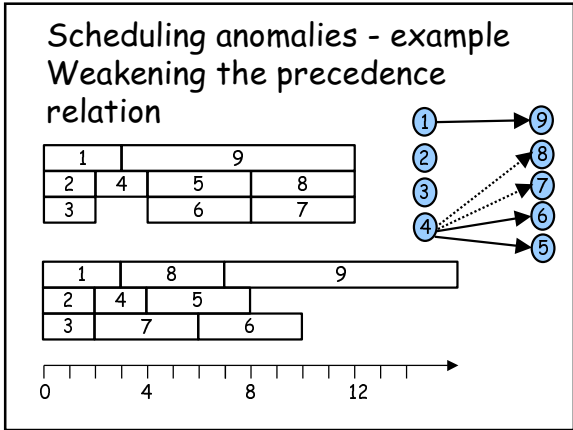

Multiprocessor Scheduling is NP-complete

- INSTANCE: a set J of tasks, a number m of processors, a global deadline d , and for each $j \in J$, a computation time C_j .
- QUESTION: is there a partition $J = J_1 \cup J_2 \cup \dots \cup J_m$ such that $\max_{1 \leq p \leq m} \sum_{j \in J_p} C_j \leq d$?

[Garey & Johnson: Computers and Intractability. A Guide to the Theory of NP-Completeness]

Where's the catch?

- Theorem [Graham, 1976]:
If a task set is optimally scheduled on a multiprocessor with some priority assignment, fixed execution times, and precedence constraints, then the following can increase the schedule length...
- Priorities are a bad idea! They confuse two concepts:
 - How important is something?
 - What should be scheduled next?

Scheduling without Precedence Constraints

Where's the catch?

- Theorem [Graham, 1976]:
If a task set is optimally scheduled on a multiprocessor with some priority assignment, fixed execution times, and precedence constraints, then the following can increase the schedule length...
- Classical scheduling methods for multiprocessors may not be optimal, but optimality may be hard to achieve (NP-complete).

Earliest Due Date (EDD)

$1 | \text{synch} | L_{\max}$

Use when:

- Synch: all jobs have $r=0$ (arrive immediately)
- Optimizes maximum lateness
- No precedence relations
- No preemption necessary

Earliest Due Date (EDD)

Given a set of processes
 $\{[C_1, d_1], [C_2, d_2], \dots, [C_m, d_m]\}$,
 in order to minimize L_{max} it suffices to schedule
 the processes in order of increasing deadlines.

• **EDD Algorithm:**

- 1) Sort the deadlines in increasing order
- 2) Schedule the processes in order of increasing deadline.

• **Schedulability criterion:**

Once ordered so that $d_1 < d_2 < \dots < d_m$, check
 that $\sum_{i=1}^k C_i < d_k$ for all $k \in \{1, \dots, m\}$.

EDF Algorithm

[Horn]: to minimize L_{max} , always
 execute the process that has the
 earliest deadline

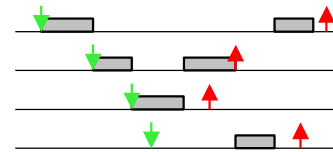

EDD Optimality

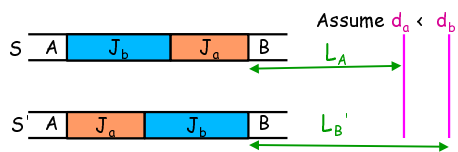

$$\begin{matrix} L_a' < L_a & L_A' = L_A \\ L_b' < L_b & L_A' = L_A \end{matrix}$$

Hence

$$L' = \max \{L_a', L_b', L_A', L_B'\} < L = \max \{L_a, L_b, L_A, L_B\}$$

Proof of EDF Optimality

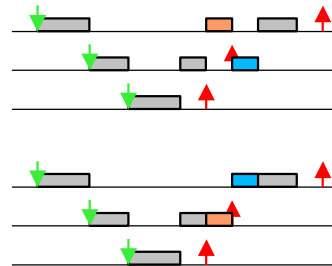

Earliest Deadline First (EDF) $1|asynch|L_{max}$

Use when:

- Tasks can have arbitrary arrival time.
- They are preemptable. This is important!

Scheduling with Precedence Constraints

Scheduling with precedence constraints (1 | prec,syn | Lmax): LDF (Latest Deadline First)

- Build the schedule from last to first, by recursively:
 - Let Q be the subset of jobs all whose descendants have been scheduled.
 - Pick the job p from Q that has the latest deadline.
 - Add p to the front of the schedule.
- Should be really called LDL (Latest deadline last).
- Optimal wrt. L_{max} .

LDF Example

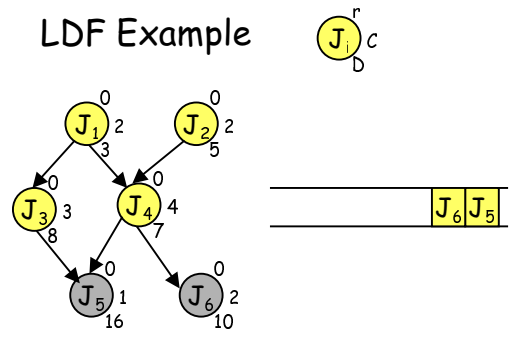

LDF Example

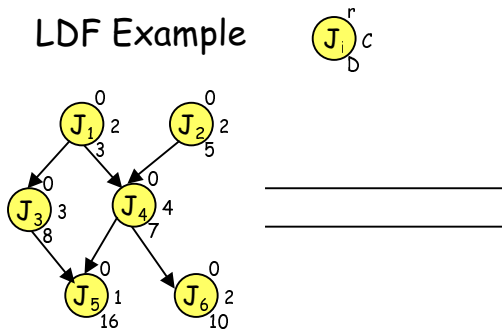

LDF Example

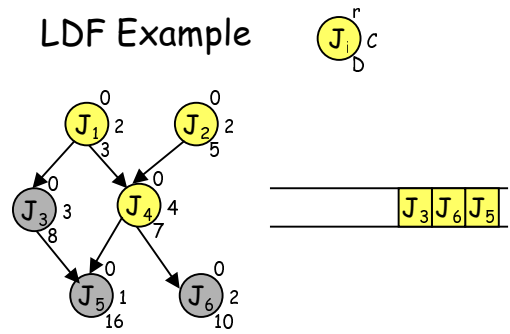

LDF Example

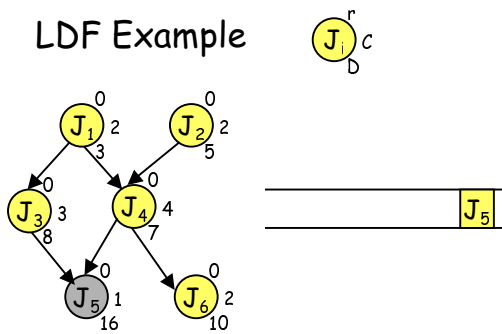

LDF Example

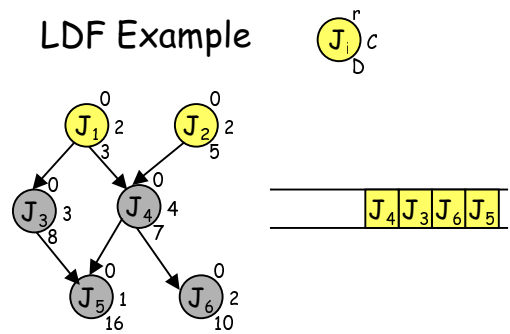

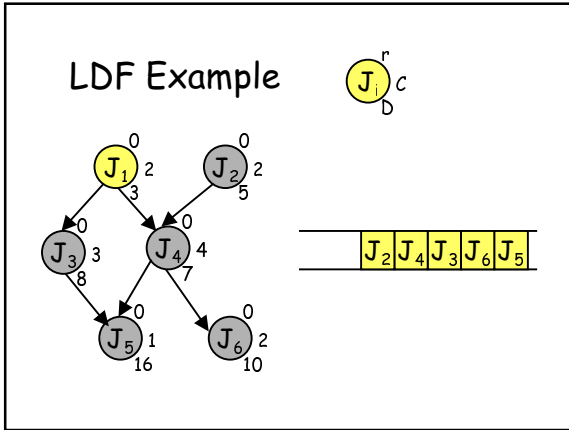

EDF with precedence constraints (1 | async, prec, preem | Lmax)

- Algorithm by Chetto, Silly, Bouchenouf (1990).
- Idea: transform timing constraints to enforce precedence (cannot start before predecessors, cannot pre-empt successors), then use EDF.

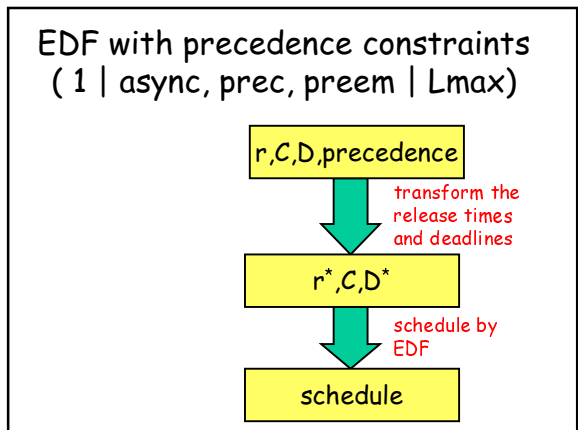
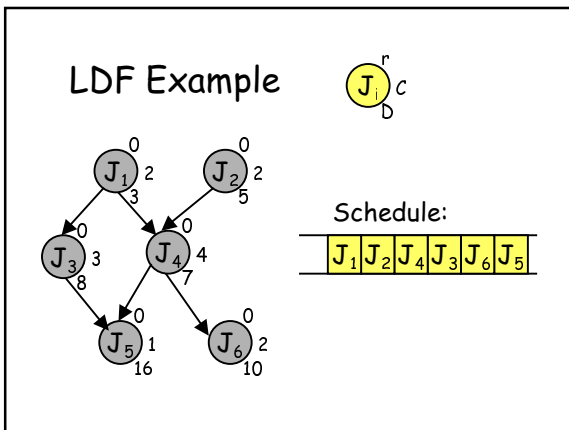

LDF: Proof of Optimality

J_a should be last according to LDF

$L_{\max} = \max \{L_A, L_B, L_a, L_b\}$

L_A unchanged

$L'_B \leq L_B$ as B starts earlier

$L'_b \leq L_b$ as J_b starts earlier

$L'_a = f'_a - d_a \leq f_b - d_b$ (as $d_a > d_b$) = L_b

So $L'_{\max} \leq L_{\max}$

The argument is concluded by induction.

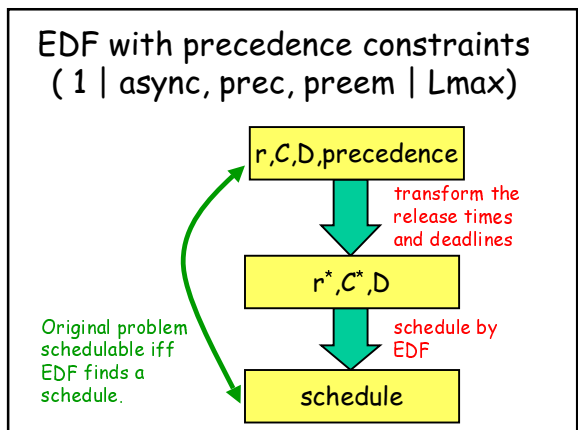

EDF with precedence constraints (1 | async, prec, preem | Lmax)

- When $J_a \prec J_b$, then:
 - $s_b \geq r_b$ (J_b must start after being released)
 - $s_b \geq r_a + C_a$ (so J_a has time to finish)
- Thus, replace r_b by $r_b^* = \max\{r_b, r_a + C_a\}$

EDF: Modification of the Deadlines

- Algorithm for deadline modification:
 - For all sinks J_a of dependency graph, let $d_a^* = d_a$.
 - Select a task J_b such that all successors of J_b have already been modified; let H be this set.
 - Let $d_b^* = \min\{d_b, \min_{c \in H} (d_c^* - C_c)\}$
- And recur.

EDF with precedence constraints (1 | async, prec, preem | Lmax)

- Algorithm for release times:
 - For all roots J_a of dependency graph, let $r_a^* = r_a$.
 - Select a task J_b such that all predecessors of J_b have already been modified; let H be this set.
 - Let $r_b^* = \max\{r_b, \max_{c \in H} (r_c^* + C_c)\}$
- And recur.

EDF Modification Example

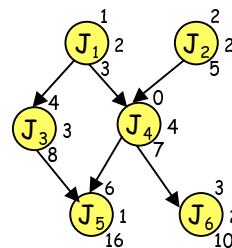

EDF: Modification of the Deadlines

- Given J_a and J_b s.t. $J_a \prec J_b$, then the following conditions must hold:
 - $f_a \leq d_a$ (or else we miss the deadline)
 - $f_a \leq d_b - C_b$ (or there won't be enough time for a to finish).
- Hence, replace d_a by $d_a^* = \min\{d_a, d_b - C_b\}$

EDF Modification Example

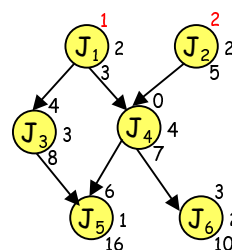

EDF Modification Example

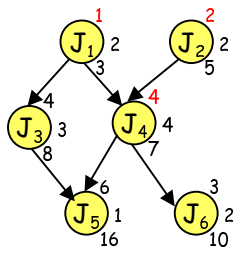

EDF Modification Example

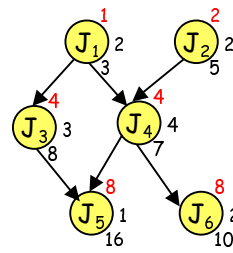

EDF Modification Example

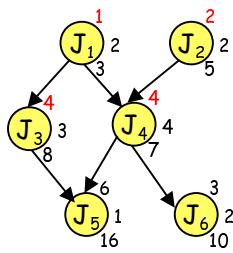

EDF Modification Example

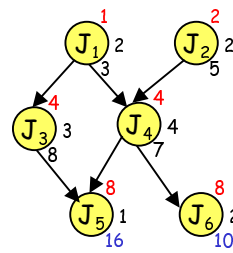

EDF Modification Example

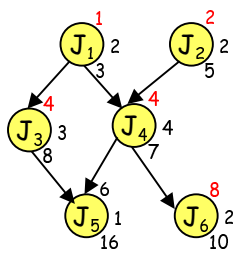

EDF Modification Example

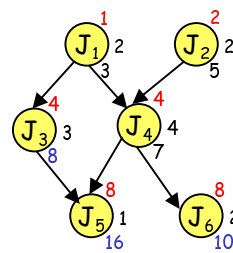

EDF Modification Example

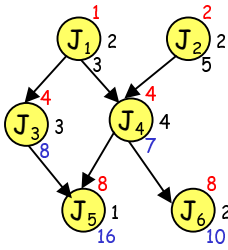

Another Example

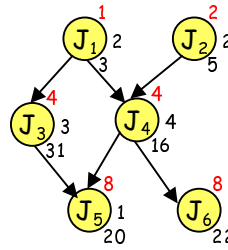

EDF Modification Example

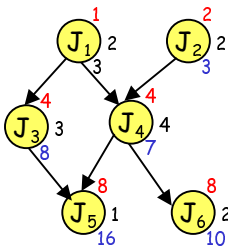

Sometimes we can see right away that the problem is not schedulable

Another Example

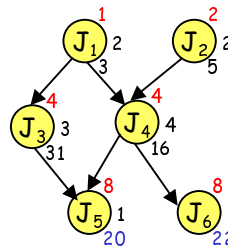

Another Example

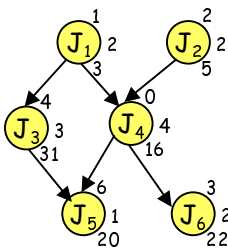

Another Example

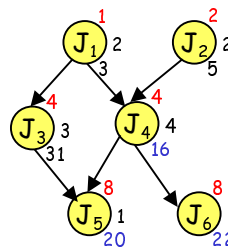

Another Example

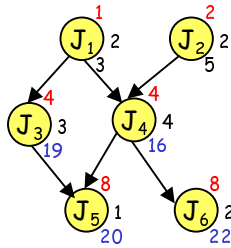

EDF + prec: Proof of optimality

- The algorithm provides a translation EDF+Prec 1 modified-EDF.
- We can show that the translation preserves schedulability.
- First direction: if EDF+Prec is schedulable, then modified-EDF is also schedulable (the same schedule works).

Another Example

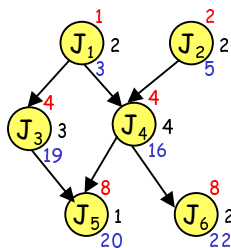

EDF + prec: Proof of optimality

- Converse: if modified-EDF is schedulable, the same schedule shows that EDF+Prec is schedulable.
- Clearly, the schedule produced by modified EDF meets all release times and deadlines of the original problem; we must only prove that the precedence relation is respected.
- Assume $J_a \prec J_b$, and $C_b > 0$. Then, $D_a^* < D_b^*$, and $r_a^* < r_b^*$, so EDF schedules J_a before J_b .

Another Example

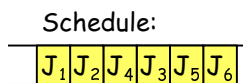
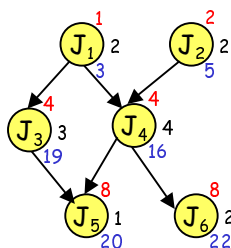

Schedulable.

Non-Preemptive Scheduling

- Jobs have release times, arrive dynamically, and there are no precedence relations.
- There are two kinds of algorithms:
 - Non-idle, that always execute a job as long as there is one ready
 - May-Idle, that may choose to do nothing even though there are jobs ready.
- There are cases when may-idle algorithms outperform non-idle ones....

Being idle is sometimes a good idea

But: unless the arrival times are known, are may-idle algorithms reasonable? They require knowledge about the future!

EDF is best of non-idle $1|async|L_{max}$ algorithms

- This is a theorem by Jeffay, Stanat, and Martel (1991).
- Intuition: if you can't help being active, at least do the most useful thing at hand, that is, the one with the earliest deadline.

Aperiodic scheduling: summary

	sync	preempt async	non-preempt async
independent	EDD	EDF	if non-idle, EDF
prec constr.	LDF	EDF with modificati ons	Search